



REGULATIONS OF THE COAL INDIA HOCKEY INDIA LEAGUE

OCTOBER 2016

REGULATIONS OF THE COAL INDIA HOCKEY INDIA LEAGUE

Contents

Page

1	Regulations of the Coal India Hockey India League	2
2	League Officials	2
3	Team Entry	2
4	Pre-competition Briefing Meetings	3
5	Composition of a Team	3
6	Team Clothing, Equipment and Colours	5
7	Duration of Matches	6
8	Team Benches	6
9	Substitution of Players	7
10	Admission to the Field of Play	7
11	Interruptions of a Match	8
12	Match Reports	8
13	Disqualification or Failure to Play	9
14	Code of Conduct and Sanctions	9
15	Protests	9
16	Appeals Procedure	10
17	Anti-Doping	11
18	Video Umpire	12
19	Unforeseen Events	12

Appendices

1	Competition Plan and Ranking	13
2	Schedule of Variations to the Rules of Hockey	18
3	Team Entry Form	21
4	Uniform Advertising	22
5	Video Umpire Procedures	25
6	Breach of Overseas Player Numbers	28

1. REGULATIONS OF THE COAL INDIA HOCKEY INDIA LEAGUE

- 1.1 The Coal India Hockey India League (Coal India HIL) is an annual event held in India and sanctioned by the International Hockey Federation (FIH).
- 1.2 The Coal India HIL will be conducted in accordance with the Coal India HIL Competition Plan - see **Appendix 1**.
- 1.3 The Coal India HIL will be conducted in accordance with the Rules of Hockey in force on the first playing day of the League except as contained within these Regulations or as varied by **Appendix 2** to these Regulations.
- 1.4 The Coal India HIL Regulations will be published on the Hockey India League website (www.league.hockeyindia.org). A copy of these Regulations will be sent to the participating teams by Hockey India prior to the start of the League. In addition, Hockey India will make copies available for the participating teams and the tournament officials at the pre-competition briefing meetings.
- 1.5 The HI/ Coal India HIL Code of Conduct, established to create awareness of and accountability for the promotion of the game of hockey amongst all Coal India HIL participants, will apply in full at all times. This document will be made available to all Coal India HIL participants.
- 1.6 The Coal India HIL Image Rights Policy, established to allow Coal India HIL and Hockey India to use images taken during Coal India HIL, will apply in full at all times. The policy is included in the Coal India HIL Code of Conduct and will be made available to all Coal India HIL participants.

2. LEAGUE OFFICIALS

- 2.1 A Tournament Director shall be appointed by Hockey India. The Tournament Director shall have the full power and authority in relation to all technical matters concerning the conduct of all participants in the Coal India HIL in accordance with the Rules of Hockey and these Regulations.
- 2.2 The Tournament Director shall appoint the Umpires (including the Video Umpire when applicable), Assistant Tournament Directors, Technical Officers and Judges for each match from among the persons appointed by Hockey India to officiate in Coal India HIL.
- 2.3 An official of a participating team is not permitted to be a technical official or umpire in the Coal India HIL.
- 2.4 The Tournament Director shall ensure that all participants abide by the Coal India HIL Code of Conduct and has authority to take appropriate action in accordance with the Code.
- 2.5 The Tournament Director may delegate the exercise of his powers and authorities to an Assistant Tournament Director at each Coal India HIL venue in whole or in part and for such duration as the Tournament Director deems necessary.

3. TEAM ENTRY

- 3.1 A maximum of twenty (20) players to be entered by each participating team of whom no more than 8 may be overseas (non-Indian) players. A minimum of 2 goalkeepers are allowed in the squad. See **Appendix 3** for the official Coal India HIL Team Entry Form.
- 3.2 The Official Coal India HIL Team Entry Form must be completed by all participating teams and submitted to the Coal India HIL Competitions Director no later than 05 January 2017
- 3.3 The Team Entry Form must include:
 - (a) the full names and nationality of up to **20 players** selected to participate in the Coal India HIL identified by their respective playing shirts numbered within the range 1-32;
 - (b) the name of the **Team Manager** (not being the Head Coach, Assistant Coach or Team Medical Doctor);
 - (c) the name of a **Stand-in Team Manager** (not being the Head Coach or Team Medical Doctor), who will take over the duties and responsibilities of the Team Manager if

nominated to be the Team Manager for a particular match, or if the Team Manger is incapacitated or suspended;

- (d) the name(s) of the **Head Coach, Assistant Coaches, Trainer, Physiotherapist** and **Team Medical Doctor**, if present and wishing to be authorised to sit on the team bench during a match (subject to the restrictions stated in Regulation 5);
- (e) details as to the primary and alternate colours of field players clothing (the primary set must comprise of at least 80% single colour per piece and the alternate set must consist of a colour(s) completely different from the dominant one(s) in the primary set of shirts, shorts and socks;
- (f) details as to the primary and alternate colours of goalkeeper's shirts which must consist of colours completely different from the primary and alternate colours of the teams field players shirts.

3.4 An immediate Replacement for a player may be included in the Team Entry Form in accordance with the COAL INDIA HIL Player Replacement Policy. This policy allows teams to replace players immediately who withdraw from the team due to injury, illness or personal circumstances.

4. PRE-COMPETITION BRIEFING MEETING

- 4.1 The Team Manager, Stand-in Team Manager and Head Coach must attend the pre-competition briefing meeting with Coal India HIL and the Tournament Director at the time and place notified by Coal India HIL. The Team Captain may also attend although this is optional.
- 4.2 Prior to the pre-competition briefing meeting the Team Managers are required to submit the completed Manager's Declaration forms **A** and **B** to the Tournament Director.
- 4.3 Team Managers must bring to the briefing meeting, or such other meeting(s) specified by the Tournament Director or Coal India HIL Competitions Director:
 - (a) the passports (or the national identity cards for Indian players) of players for proof of identity and nationality. The Tournament Director may require a player to attend a meeting with his passport.
 - (b) completed Acknowledgement and Agreement Forms (see **Coal India HIL Code of Conduct**) required by the Coal India HIL Code of Conduct, HI Anti-Doping Regulations, Coal India HIL Image Rights Policy and Coal India HIL Anti-Corruption Policy must be signed by each individual participant (all team members and officials, including players, managers, coaches, technical, medical and other support staff);
 - (c) samples of the clothing of their field players and goalkeepers (primary and alternate colours)
- 4.4 Team Managers must bring to the field of play, or such other place as determined by the Tournament Director, and at a time determined by the Tournament Director:
 - (a) all hockey sticks intended to be used by all players in the squad;
 - (b) all playing equipment, including any protective equipment to be used such as, but not limited to, face masks, hand protectors and knee pads worn by field players;
 - (c) goalkeepers' headgear, hand protectors, leg guards and kickers.

5. COMPOSITION OF A TEAM

- 5.1 It is a requirement that 20 players must be named and present for each match, of whom **2 must be goalkeepers** wearing full protective equipment. It is compulsory that each team must have a second goalkeeper available for each game they play in case of injury or suspension to the goalkeeper on the pitch.

- 5.2 In relation to 5.1, the only exemption for this requirement will be if a player(s) is injured or ill, and this is certified by an independent medical professional.
- 5.3 If a player(s) is suspended by the Tournament Director for one or more matches then, only for those matches, the number of players the team may use will be reduced by the number of players suspended.
- 5.4 No less than 2 and no more than 5 overseas (non-Indian) players may be on the pitch for each team at any time during the match, including the goalkeeper (also see Clause 9.4 regarding substitutions). If a shoot-out is played in a play-off match, no more than 3 overseas players may be used by each team to take a shoot-out. During a shoot-out, the goalkeeper can be of any nationality.
- 5.5 Each team must have a **Team Captain** who is responsible for the behaviour of the team players on the field of play or on the team bench during a match. The Team Captain must wear a distinctive armband at all times during a match. Upon suspension of the Team Captain, another player on the field of play or the team bench must take the armband and assume the role of Team Captain.
- 5.6 No later than sixty (60) minutes before the start of a match, each Team Manager must complete and submit in person the Coal India HIL Team Declaration Form for that match to the appointed Assistant Tournament Director nominating:
- (a) the eleven (11) players who will be on the field of play at the commencement of the match (see also clause 5.4 above);
 - (b) the starting positions for the nominated players for the purpose of broadcast;
 - (c) up to nine (9) players who are to start on the team bench (unless one or more players have been suspended for that game in which case the number of players is reduced accordingly - see clause 5.3 above);
 - (d) the Team Captain and goalkeepers for the match;
 - (e) the Team Manager for the match;
 - (f) the Coach on the bench for the match;
 - (g) a Physiotherapist;
 - (h) a Medical Doctor;
 - (i) a representative of the Franchise Management (optional).
- 5.7 Nominations can only be made from the players and team officials whose names appear on the Coal India HIL Team Entry Form (see **Regulation 3**), excluding any person who has been suspended from participating in the match by the Tournament Director.
- 5.8 The remaining team support staff (whose names appear on the Coal India HIL Team Entry Form), with the exception of suspended players (if any), may warm-up and practice with their team up to 10 minutes prior to the scheduled start time of the match. The Team Manager shall be responsible to ensure that these support staff leave the pitch and remain outside the field of play until the match is finished, subject to them being allowed to return to the field of play at half time (only), and during a shoot-out competition in a playoff match only (if applicable).
- 5.9 A nominated player who becomes injured or incapacitated during warm-up or practice may be replaced by a player whose name appears on the Coal India HIL Team Entry Form up to 10 minutes prior to the scheduled start time of the match. The Team Manager must notify the Technical Officer on duty accordingly, who will inform the Assistant Tournament Director for further action. Changes within 10 minutes of the start time will only be permitted in exceptional circumstances agreed with the Tournament Director, or in his absence, the Assistant Tournament Director on duty at the venue.

6. TEAM CLOTHING, EQUIPMENT AND COLOURS

- 6.1 The Tournament Director, at his absolute discretion, shall advise the Team Managers of the colours of clothing of their field players and goalkeepers for each match.
- 6.2 During a match each team (field players and goalkeepers) must wear the colours of its team as directed by the Tournament Director.
- 6.3 Any additional items of clothing such as under shirts or cycle shorts, worn by a player during a match must be of the same colour specified for the adjoining piece of clothing.
- 6.4 When warming up on the sideline during a match, substitutes must wear bibs or some other form of clothing in a different colour to both teams and to the umpires.
- 6.5 Goalkeepers must wear a shirt of a colour different from that of their own team and that of their opponents.
- 6.6 Each player's number must remain the same throughout the Coal India HIL for that season and must be the same as that submitted on the Coal India HIL Team Entry Form (see **Regulation 3**).
- 6.7 Each player's number must appear in filled (not outline) distinctive figure(s) and be of a contrasting colour to their shirt and shorts. The number must be:
 - (a) not less than 16cm and not more than 20cm in height, on the back of the player's shirt;
 - (b) not less than 7cm and not more than 9cm in height, on the front of the player's shorts at thigh level - left leg (field players);
 - (c) not less than 7cm and not more than 20cm in height, on the front of the goalkeeper's shirt.
- 6.8 The player's name must appear in filled (not outline) distinctive letters not less than 6cm and not more than 10cm in height on the back of each player's shirt, positioned above the player's number so that the number remains clearly visible.
- 6.9 Each team involved in a match must have available at the venue two (2) spare sets of players clothing without number, plus suitable material for numbering in an emergency.
- 6.10 All players must be uniformly and neatly dressed at all times during a match.
- 6.11 Field players:
 - (a) must wear shin guards inside the socks and below the knee at all times during a match;
 - (b) must wear any body protection (including leg protection) underneath normal playing clothing; knee pads may be worn outside the socks provided that the colour of the knee pads is the same as the colour of the socks.
 - (c) are permitted to wear a face mask while defending a penalty corner provided that the face mask has a smooth surface, conforms to the Rules of Hockey, and is approved by the Tournament Director in advance;
 - (d) must not wear any additional protective equipment for medical reasons or similar as specified in the Rules of Hockey unless requested in writing by the Team Medical Doctor (with medical certificate) and approved by the Tournament Director.
- 6.12 No advertisement may appear on any item of clothing or equipment used by any player, team official, umpire or technical official except as may be permitted by Coal India HIL during a match, including warm-up and cool-down periods in accordance with **Appendix 4**.

- 6.13 Manufacturer identification(s) on a particular item of clothing worn by players or equipment used by players whilst playing may be permitted by Coal India HIL in accordance with **Appendix 4**.
- 6.14 A player on the field of play must not use or be equipped with any device to receive communication.

7. DURATION OF MATCHES

- 7.1 A match consists of 4 periods of 15 minutes
- At the end of the first and third period there shall be an interval of 2 minutes. During this interval, team are not permitted to leave the field of play.
- Play is resumed by a centre pass. For the second period this is taken by the team that started the first period. For the fourth period the centre pass is taken by the team that started the third period.
- At the end of the second period there shall be an interval of 10 minutes. During this interval teams may leave the field of play. Play is resumed by a centre pass which is taken by the team that did not take the centre pass for the first period. Teams will change ends at half time only.
- 7.2 If the scores are equal at the end of regulation time in a play-off match, shoot-outs will be played in order to establish an outright winner of the match as outlined in **Appendix 1**.
- 7.3 The Umpires will blow a whistle to start and re-start the match, they will also signal to the Technical Officials on duty every time stoppage they order and the subsequent re-starts.
- 7.4 Time keeping is controlled by the Technical Officials on duty. They are responsible for signalling the end of each quarter. If a match is prolonged at the end of a regulation time period to allow for the completion of a penalty corner as specified in the Rules of Hockey, the Umpires will signal the end of that period.

8. TEAM BENCHES

- 8.1 Team benches shall be situated near to, and on the same side of the field of play, as the technical officials table.
- 8.2 The Team Manager, Physiotherapist, Team Medical Doctor and nine (9) substitute players nominated for that match, plus the Franchise Representative (if registered), must remain seated at the team bench during playing time, including time stoppages, unless the Technical Officer on duty or Umpire(s) direct otherwise, or when implementing substitution procedures.
- 8.3 The nominated Team Manager, who is responsible for the conduct of all persons occupying the bench, must be present on the bench during the match and must occupy the seat nearest to the technical officials' table.
- 8.4 The Coach nominated for the match must remain on their team bench or in the designated area in front of the team bench.
- 8.5 Substitutes may leave the team bench to warm up in an area designated by the Technical Officer on duty (see also clause 6.4).
- 8.6 The Team Medical Doctor, Physiotherapist or other team medical staff may leave their seats to treat players as required.
- 8.7 Vocal communication by team officials and/or players on the team bench must not be directed at the technical officials seated at the table, the Umpires and/or the players of the opposing team.
- 8.8 The Technical Officer on duty, after warning a Team Manager of acts of misconduct by a person or persons on that team bench, is empowered, should misconduct continue, to suspend the person or persons from further participation in the game and to order that person or persons to leave the

team bench for the remainder of the match. Further disciplinary action may be taken by the Tournament Director after the match, depending upon the circumstances.

- 8.9 If the Team Manager is suspended the Stand-in Team Manager must occupy the team bench and take over the duties and responsibilities of the Team Manager.

9. SUBSTITUTION OF PLAYERS

- 9.1 Substitution of player(s) takes place as specified in the Rules of Hockey from the players nominated for that match, subject to the provisions of clause 5.3 above.
- 9.2 In accordance with the Rules of Hockey (2.3.a) a substitution is permitted at any time except within the period from the award of a penalty corner until after it has been completed. During this period substitution is only permitted for injury to or suspension of the defending goalkeeper or defending player with goalkeeping privileges.
- 9.3 Team Managers' are responsible for advising the Technical Officer on duty of the substitution of any overseas (non-Indian) players during the match, and submitting the relevant overseas player's card at the time of substitution. Any breach of this regulation will be penalised (see Appendix 6).
- 9.4 The substitution will be carried out under the supervision of the Technical Officer on duty.
- 9.5 After leaving the field of play having been substituted, a player must immediately go to his team bench.
- 9.6 Any player, upon being suspended, may not be substituted or used as a substitute during the period of suspension.
- 9.7 Team Managers are responsible for the proper application of these procedures.

10. ADMISSION TO THE FIELD OF PLAY

- 10.1 The team officials and reserve goalkeepers need the permission of the Umpires to enter the field of play. This regulation is obligatory, even in the event of a player or an Umpire becoming incapacitated.
- 10.2 The Coach on the team bench **may not** enter the field of play at any time under any circumstances except during quarter/half time breaks, time-outs and during any shoot-out competition.
- 10.3 No incapacity treatment will be permitted on the field of play. If a player becomes incapacitated on the field of play, one of the Umpires may stop the match and assess whether or not the player requires attention:
- (a) (i) The Umpire may authorise the registered Team Medical Doctor and /or Physiotherapist and/or other team medical staff to enter the field of play;
- (ii) if a team does not have such registered officials, the Umpire will authorise the on-duty COAL Medical Officer/Doctor and/or the Team Manager, to enter the field of play;
- (iii) if necessary, the Umpire may also authorise stretcher bearers to enter the field of play;
- (iv) persons authorised to enter the field of play are required to assist and remove the player concerned from the field of play as soon as it is safe to do so.
- (b) If any person from the team bench and/or the on-duty Medical Officer/Doctor enters the field of play to attend to a player:
- (i) that player must leave the field of play and return to the team bench area for a minimum of two (2) minutes.
- (ii) the two minute period will be managed by the technical officials on duty;

- (iii) the player required to leave the field may be substituted, subject to the provisions in the Rules of Hockey.
- 10.4 If a player sustains an injury which causes bleeding, then that player must leave the field of play as soon as possible and shall not re-enter until the bleeding has stopped and the wound is adequately covered. Blood stained clothing must be replaced and equipment cleaned before re-entry to the field of play.
- 10.5 If blood staining to the field of play occurs cleaning must immediately take place using a Non-Acid Disinfectant Surface Cleaner which is effective against antibiotic-resistant bacteria or, if such a material is not available, an 80% alcohol solution. During this operation there must be a time stoppage of play.
- 10.6 No liquid or other refreshment may be consumed on the field of play. Any player wishing to take refreshment during a match, including during time stoppages, must leave the field of play and is permitted to re-enter as specified in the Rules of Hockey. A goalkeeper may leave and re-enter the field of play only adjacent to the goal.
- 10.7 Team officials and players may leave the technical facility area surrounding the field of play during half time, only with prior permission of the Technical Officer on duty. In doing so, players must leave their sticks and goalkeepers their sticks, hand protectors and headgear, at or near the team bench and must return not less than two minutes before the match is due to be restarted.
- 10.8 Team officials and players will not leave the field of play or team bench area at quarter time breaks.
- 10.9 At the end of the match, all team officials and players must leave the field of play through the Media Mixed Zone and must make themselves available for comment as required.
- 10.10 Audible vocal communication from the team videographer facility overlooking the field of play is not permitted by those persons authorised to use this facility.

11. INTERRUPTIONS OF A MATCH

- 11.1 If a match is interrupted by the Umpires (e.g. because of weather or field of play conditions) or by the Technical Officer because of thunderstorm with lightning, this match must be resumed as soon as possible (ideally, but not necessarily, on the same field of play on the same day), under the following conditions:
- (a) the match must be completed up to the regulation full time (see Clause 7.1) or the completion of shoot-outs as appropriate (see Clause 7.4), the score on the resumption being that at the time the interruption took place;
 - (b) the restart on resumption is at the place where play was interrupted and with the decision taken at the moment of interruption or in the event of no decision having been taken, with a bully;
 - (c) on resumption, Regulation 9 relating to the substitution of players shall apply as though there had been no interruption to the match.

12. MATCH REPORT

- 12.1 At the end of the match, a Match Report is produced by the appointed technical officials. This is a summary of the match showing the names of all players, team officials and the technical officials nominated for the match, and includes the match result and key match statistics.
- 12.2 The Team Manager of each team must sign the Match Report within 10 minutes of the end of the match.
- 12.3 The match officials must also sign the Match Report once both Team Managers have done so. Once the Match Report is signed by all required persons, the result and details on the signed Match Report will be declared official.

12.4 See **Regulation 15** regarding end of match protests.

13. DISQUALIFICATION OR FAILURE TO PLAY

13.1 During the pool matches:

- (a) a team which fails to start a match at the specified and agreed time, or fails to complete a match to regulation time, unless for reasons as specified in **Regulation 11**, will be deemed to have lost the match by 5-0, such result to be recorded as the official result of the match in question;
- (b) a team which fails to start or complete a second or subsequent match will be deemed to have withdrawn from Coal India HIL. Under these circumstances, the results and scoring records of any previous matches already played by that team will be removed from the records and the pool points table shall be adjusted accordingly.

13.2 During play-off matches:

- (a) a team which fails to start a play-off match at the specified and agreed time, or fails to complete a play-off match to regulation time (including any shoot-outs if appropriate), unless for reasons as specified in **Regulation 11**, will be deemed to have lost the match and will take no further part in Coal India HIL that season.

13.3 Any team which is subject to the penalties in Clauses 13.1 or 13.2 may be subject to further disciplinary action as determined by the Coal India HIL.

14. CODE OF CONDUCT AND SUSPENSIONS

14.1 The **HI/ Coal India HIL Code of Conduct**, established to create awareness of and accountability for the promotion of the game of hockey amongst all Coal India HIL participants, will apply in full at all times.

14.2 The Tournament Director has authority to reprimand or suspend for one or more matches any players, team officials and other officials who, in their opinion, commit a breach of the COAL INDIA HIL Code of Conduct before, during or after a match, wherever that misconduct occurred, in accordance with the Coal India HIL Disciplinary Penalties - see **Coal India HIL Code of Conduct**.

14.3 In deciding the duration of any suspension, the Tournament Director is not limited to the remaining Coal India HIL matches in the current season but may impose a suspension which has effect for matches beyond the conclusion of Coal India HIL. Coal India HIL may, in its absolute discretion, impose further penalties on an individual or a team.

14.4 Such suspended persons may not enter the field of play, or the technical facility areas (including the team bench, Coach's boxes and video tower), at any time before or during a match for which they are suspended, including during quarter and half time breaks, and any periods of extra time or shoot-out competition, until completion of the match or matches comprising the suspension.

14.5 It is the duty of the Tournament Director to adjudicate upon, and if appropriate to impose penalties in respect of any disciplinary matters which may occur during the match *before* the Tournament Director and the specific participants leave the match venue (in accordance with the powers granted to a Tournament Director by the Coal India HIL for the purposes of these Regulations).

14.6 In all cases where the Tournament Director is not present at the venue, such authority under this regulation may be delegated to the Assistant Tournament Director at the venue.

15. PROTESTS

15.1 If a team wishes to lodge a protest at the end of a match or at the end of a shoot-out competition, the Team Manager must:

- (a) declare the intention to do so immediately in writing directly below his signature when signing the Match Report or shoot-out competition result form;

- (b) submit in writing using the **Coal India HIL Protest Submission Form** the grounds of the protest and hand that document to the Technical Officer on duty within 30 (thirty) minutes of the completion of the match or stand alone shoot-out competition;
- (c) deposit Fifty Thousand Rupees (INR 50,000), or equivalent in USD, GBP or Euro, with the same Technical Officer within 30 (thirty) minutes of the completion of the match or stand alone shoot-out competition.

Failure to comply with any part of this regulation will result in the dismissal of the protest.

- 15.2 Notwithstanding the provisions of this regulation, no protest can be lodged from a field of play decision made by the Umpires (including the Video Umpire where applicable).
- 15.3 If a protest is made, the Technical Officer on duty must immediately inform the Tournament Director, or in his absence, the Assistant Tournament Director at the venue.
- 15.4 The Tournament Director must make a decision in writing and publish this within two (2) hours from the submission of the protest. The Tournament Director should also verbally notify the decision to the Team Manager concerned immediately after making the decision. The Team Manager should make arrangements with the Tournament Director to be available to receive the decision when made.
- 15.5 In all cases where the Tournament Director is not present at the venue, such authority under this regulation may be delegated to the Assistant Tournament Director at the venue.
- 15.6 The deposit will be refunded if the protest is either dismissed or allowed. The deposit will be retained in full or in part by Coal India HIL if the protest is not allowed, although Coal India HIL may subsequently decide to return all or part of the deposit either at that time, or at some point in the future.
- 15.7 If a team wishes to appeal the decision of the Tournament Director resulting from any protest made under these Regulations, the Team Manager concerned should follow the conditions outlined below in **Regulation 16**.

16. APPEALS

- 16.1 An individual or a team may lodge an appeal against:
 - (a) a decision by the Tournament Director to suspend a player, team official or other official;
 - (b) a protest which has not been allowed by the Tournament Director.
- 16.2 If an individual or a team wishes to appeal the decision of the Tournament Director, the Team Manager must submit written notice to the Tournament Director, or in his absence, the Assistant Tournament Director at the venue, within sixty (60) minutes after the Tournament Director's original decision is published. If no such appeal is lodged, the original decision of the Tournament Director is final.
- 16.3 If the appeal is against a decision by the Tournament Director to suspend a player or team official, a deposit of Fifty Thousand Rupees (INR 50,000), or equivalent in USD, GBP or Euro must accompany the written notice of appeal.
- 16.4 The written notice of appeal must be submitted using the **Coal India HIL Appeal Submission Form** and must contain a statement outlining the grounds of the appeal and indicating whether the appeal is against:
 - (a) a finding;
 - (b) a penalty imposed;
 - (c) both a finding and a penalty;
 - (d) procedural irregularities of a Tournament Director's hearing.

- 16.5 If an appeal is so lodged, the Tournament Director must immediately inform the COAL INDIA HIL Competitions Director who will convene the **Coal India HIL Appeal Panel** to consider the matter fully in accordance with this Regulation.
- 16.6 The Coal India HIL Appeal Panel will consist of a minimum of three (3) persons and a maximum of five (5). Any person who has taken part in any previous proceedings relating to the matter under appeal may not be appointed to that Appeal Panel.
- 16.7 The Coal India HIL Appeal Panel will consider the appeal within eighteen (18) hours of the receipt of the appeal by the Tournament Director. It may be that the members of the Appeal Panel will not be present at the same venue, but will communicate electronically or by telephone.
- 16.8 No team or individual is entitled to a personal hearing before the Appeal Panel, but may make representations in writing (electronically) provided these are received within the time limit notified to the appealing Team Manager by the Coal India HIL Competitions Director.
- 16.9 The appeal is not to be considered a re-hearing of the evidence. It is limited to a review of the decision made by the Tournament Director to ensure compliance with the Regulations, Code of Conduct and principals of natural justice.
- 16.10 No fresh evidence shall be presented to the Appeal Panel without its approval. If approval is sought to present fresh evidence, particulars of such evidence and the reasons why it was not presented earlier must also be included in the written notice of appeal.
- 16.11 The Appeal Panel has the power:
- (a) to allow or dismiss the appeal;
 - (b) to vary the decision of the Tournament Director;
 - (c) to increase, decrease or otherwise vary any penalty included in the decision of the Tournament Director;
 - (d) to impose such other penalty or sanction as it deems appropriate;
 - (e) to order that the deposit be refunded in whole, in part, or forfeited;
 - (f) to make an order for payment of costs.
- 16.12 The Appeal Panel will make a decision and publish it in writing as soon as possible but not later than 2 hours before the start of the first match on the next day that matches are played. If possible, the Convenor of the Appeal Panel which heard the case should verbally notify the Tournament Director and the Team Manager or official who lodged the appeal immediately after making the decision.
- 16.13 The decision of the Coal India HIL Appeal Panel is final and binding on all parties concerned.

17. ANTI-DOPING

- 17.1 All anti-doping tests will be carried out strictly in accordance with the World Anti-Doping Agency (WADA) Code and the HI Anti Doping Policy in force on the first playing day of the League.
- 17.2
- (a) All matches will be subject to anti-doping testing as the National Anti-Doping Agency of India (NADA) may direct.
 - (b) Team Managers will be advised of details of the anti-doping testing procedure at the pre-competition briefing meeting.
- 17.3 Any player nominated for a selected match may be subjected to an anti-dope test after the match even if that player has remained on the team bench throughout that match. A player may be subjected to more than one anti-dope test during the Coal India HIL.
- 17.4 A player selected for an anti-dope test may not take a shower, bath, ice bath or similar before providing a urine/blood sample which meets the requirements in the International Standard for Testing.

- 17.5 A positive test or a refusal to submit to a test will render the player concerned and the player's team and officials subject to the disciplinary provisions as to sanctions and penalties, and the procedures and rights as stated in the WADA Code and the current HI Anti-Doping Policy.
- 17.6 All players, team officials and League officials must sign the Acknowledgement and Agreement form included in the **Coal India HIL Code of Conduct**.

18. VIDEO UMPIRE

- 18.1 Video Umpiring will be utilised in all matches (including any shoot-outs required).
- 18.2 The Video Umpire procedures can be found in **Appendix 5**.

19. UNFORESEEN EVENTS

- 19.1 If during any Coal India HIL match circumstances arise which are not provided for in these Regulations, they will be determined by the Tournament Director after consulting with the Coal India HIL Competitions Director.
- 19.2 If any team or individual affected by the decision of the Tournament Director under this Regulation wishes to appeal, they may do so following the procedures set out in **Regulation 16**.

APPENDIX 1 - LEAGUE COMPETITION PLAN AND RANKING

1. PLAN OF THE LEAGUE

1.1 There will be six (6) teams in Coal India HIL 2017. Each Coal India HIL team shall play two (2) matches against each other team in Coal India HIL, one at their home venue and one at the venue of the opposition team. These matches will be played between 21 January and 26 February 2017.

1.2 Points will be awarded as follows:

Win:	Five (5) points
Draw:	Two (2) points
Loss with goal difference of 2 or less goals:	One (1) point
Loss with goal difference of 3 or more goals:	Nil (0) points

For every Field Goal and a Penalty Stroke Goal scored in a match other than resulting from a Penalty Corner (see below)	2 Goals
For every Penalty Corner scored in a match	1 Goal
For every goal scored from a Penalty Stroke resulting from a Penalty Corner situation.	1 Goal
In a shoot-out competition a goal from a direct Shoot-out and a Penalty Stroke	1 Goal

1.3 Teams will be ranked according to the number of points each has accumulated in the Coal India HIL. The teams finishing in 5th and 6th positions will be placed 5th and 6th accordingly in the Coal India HIL final ranking. Teams finishing 1st to 4th will enter a play-off competition (see **Paragraph 2** of this Appendix) to determine the top four ranking positions.

1.4 If at the end of the League two or more teams have the same number of points for any place, these teams will be ranked according to the following order:

- respective number of matches won;
- respective goal difference (goals for less goals against). A positive goal difference always takes precedence over a negative one;
- respective number of goals scored;
- the cumulative results of the two matches played between those two teams taking firstly the points won in the two matches, secondly the goal difference, and thirdly the number of goals scored;

1.5 If more than two teams are involved, then a ranking based upon the results of the matches among (only) them shall determine their respective position (as above). If there remains equality, then the teams involved shall be ranked according to paragraphs 1.4(a), (b), (c), and (d) of this Appendix.

1.6 Should there still remain equality between two teams, then the ranking will be determined by a shoot-out competition between those teams in accordance with **Paragraph 3** of this Appendix.

1.7 If more than two teams are involved, then each team will play a shoot-out competition against the other teams (in the same order of play as occurred in the League), in accordance with Paragraph 3 of this Appendix but with one round of five (5) shoot-outs only to be taken compulsorily by each team.

1.8 A ranking will then be established based upon the results of this round of the shoot-out competition only, with the award for each series of the respective shoot-out competitions of 3 points to the team having scored or been awarded the highest number of goals, 1 point to each team having scored or been awarded an equal number of goals and 0 points to the team having scored or been awarded the least number of goals.

- 1.9 If equality remains then teams having an equal number of points shall be ranked according to paragraphs 1.4(a), (b), (c) and (d) of this Appendix as applied to goals recorded during the shoot-out competition.
- 1.10 If an equal position of more than two teams still remains thereafter, then the same procedure shall be repeated until the teams can be ranked. The Tournament Director shall make a draw to establish each sequence of play if such further rounds of shoot-outs are required.
- 1.11 Should there be a need for a shoot-out competition under the terms described above, this will take place at a time and place to be determined by Coal India HIL on 24 February 2017.

2. PLAY-OFF MATCHES

- 2.1 After completion of the regular matches in the League, the top 4 teams will advance to the Coal India HIL Play-offs as outlined below.
- 2.2 Matches will be played as follows:

Semi-final 1:	1 st Placed Team v 4 th Placed Team
Semi-final 2:	2 nd Placed Team v 3 rd placed Team
Third/Fourth place:	Losers of the two semi-finals
Final:	Winners of the two semi-finals
- 2.3 These matches will be played on 25 and 26 February 2017 at the same venue. The venue for these matches will be Chandigarh .
- 2.4 These matches will be played to the same playing regulations as the regular Coal India HIL matches, other than outlined below in clause 2.5.
- 2.5 The score at the end of the regulation time of the above matches shall be registered by the Coal India HIL as the result of the match. However, in order to establish an outright winner of any drawn play-off match, a shoot-out competition will be conducted.
- 2.6 After a break of 4 minutes, the teams shall be involved in a shoot out competition as per **Paragraph 3** below.
- 2.7 The winner of the Final match will be crowned the **Coal India Hockey India League Champions 2017**.

3. SHOOT-OUT COMPETITION

In a shoot-out competition, five players from each team take a one-on-one shoot-out alternately against a defender from the other team as set out in this Regulation. The shoot-out competition comprises all series of shoot-outs required to determine a result.

The following sets out both the playing Rules and the procedures to be followed.

- 3.1 The respective Team Managers provide five players to take and one player to defend the shoot-outs from those on the Match Report except as excluded below. A player nominated to defend the shoot-outs can also be nominated to take a shoot-out. No substitutions / replacements are permitted during the shoot-out competition other than as specified below. See also **Regulation 5.4** regarding nationality of those players selected to participate in the shoot-out.
- 3.2 If the shoot-out competition takes place after the end of a match, the above procedures must be carried out promptly so that the first shoot-out can take place within four (4) minutes of the end of the match.
- 3.3 A player who is still serving a disciplinary suspension by the Tournament Director at the time the shoot-out competition takes place or has been excluded permanently (red card) during the match which leads to the shoot-out competition, cannot take part in that shoot-out competition. A player who has been warned (green card) or temporarily suspended (yellow card) may take part in the

shout-out competition even if the period of their suspension has not been completed at the end of the match.

- 3.4 The Tournament Director will specify the method of timing shoot-outs taking account of the facilities available and the need to control time accurately.
- 3.5 The Tournament Director will specify the goal to be used.
- 3.6 A coin is tossed; the team which wins the toss has the choice to take or defend the first shoot-out.
- 3.7 All persons listed on the Match Report other than any player who has been excluded permanently (red card) during the match which leads to the shoot-out competition are permitted to enter the field of play outside the 23m area used for the shoot-out but must be at least 10 metres from the spot where the ball is placed at the start of the shoot-out.
- 3.8 The goalkeeper / defending player of the team taking a shoot-out may be on the back-line outside the circle.
- 3.9 A player taking or defending a shoot-out may enter the 23m area for that purpose.
- 3.10 Players taking a shoot-out and also defending the shoot-outs taken by opponents are allowed reasonable time to take off their protective equipment to take their shoot-out and subsequently to put back on their protective equipment.
- 3.11 Five players from each team take a shoot-out alternately against the goalkeeper / defending player of the other team making a total of 10 shoot-outs.
- 3.12 Taking a shoot-out:
 - a the goalkeeper / defending player starts on or behind the goal-line between the goal posts;
 - b the ball is placed on the nearest 23m line opposite the centre of the goal;
 - c an attacker stands outside the 23m area near the ball;
 - d the Umpire blows a whistle to start time;
 - e an official at the technical table starts the clock;
 - f the attacker and the goalkeeper / defending player may then move in any direction;
 - g the shoot-out is completed when:
 - i 8 seconds has elapsed since the starting signal;
 - ii a goal is scored;
 - iii the attacker commits an offence;
 - iv the goalkeeper / defending player commits an unintentional offence inside or outside the circle in which case the shoot-out is re-taken by the same player against the same goalkeeper/defending player;
 - v the goalkeeper / defending player commits an intentional offence inside or outside the circle, in which case a penalty stroke is awarded and taken;

- vi the ball goes out of play over the back-line or side-line; this includes the goalkeeper/defending player intentionally playing the ball over the back-line.
- 3.13 If a penalty stroke is awarded as specified above, it can be taken and defended by any eligible player on the Match Report subject to the provisions of Articles 17, 18 and 19 of this Appendix.
- 3.14 The team scoring the most goals (or ahead by more goals than the other team has untaken shoot-outs available) is the winner.
- 3.15 A player may be suspended by a yellow or red card but not by a green card during the shoot-out competition.
- 3.16 If during a shoot-out competition (including during any penalty stroke which is awarded) a player is suspended by a yellow or red card:
 - a that player takes no further part in that shoot-out competition and, unless a goalkeeper / defending player, cannot be replaced;
 - b the replacement for a suspended goalkeeper / defending player can only come from the five players of that team nominated to take part in the shoot-out competition:
 - i the replacement goalkeeper / defending player is allowed reasonable time to put on protective equipment similar to that which the goalkeeper/defending player they are replacing was wearing;
 - ii for taking their own shoot-out, this player is allowed reasonable time to take off their protective equipment to take their shoot-out and subsequently to put it on again.
 - c any shoot-out due to be taken by a suspended player is forfeited; any goals scored by this player before being suspended count as a goal.
- 3.17 If during a shoot-out competition, a defending goalkeeper / defending player is incapacitated:
 - a that goalkeeper/defending player may be replaced by another player from among the players listed on the Match Report for that particular match, except as excluded in this Appendix or unless suspended by an Umpire during the shoot-out competition;
 - b the replacement goalkeeper:
 - i is allowed reasonable time to put on protective equipment similar to that which the incapacitated goalkeeper / defending player was wearing;
 - ii if this replacement is also nominated to take a shoot-out, this player is allowed reasonable time to take off their protective equipment to take their shoot-out and subsequently to put it on again.
- 3.18 If during a shoot-out competition, an attacker is incapacitated, that attacker may be replaced by another player from among the players listed on the Match Report for that particular match, except as excluded above or unless suspended by an Umpire during the shoot-out competition.
- 3.19 If an equal number of goals are scored after each team has taken five shoot-outs:
 - a a second series of five shoot-outs is taken with the same players, subject to the conditions specified in this Appendix;
 - b the sequence in which the attackers take the shoot-outs need not be the same as in the first series;
 - c the team whose player took the first shoot-out in a series defends the first shoot-out of the next series;

- d when one team has scored or been awarded one more goal than the opposing team after each team has taken the same number of shoot-outs, not necessarily being all five shoot-outs, that team is the winner.

3.20 If an equal number of goals are scored after a second series of five shoot-outs, additional series of shoot-outs are taken with the same players subject to the conditions specified in this Appendix:

- a the sequence in which the attackers take the shoot-outs need not be the same in any subsequent series;
- b the team which starts each shoot-out series alternates for each series.

3.21 Unless varied by this Appendix, the Rules of Hockey apply during a shoot-out.

APPENDIX 2 - SCHEDULE OF VARIATIONS TO THE RULES OF HOCKEY

1. BALL COLOUR

Rule 4.8: The ball is spherical, hard and white (or an agreed colour that contrasts with the playing surface.)

Regulation: The ball may be yellow or white as agreed with Hockey India.

2. MATCH TIME

- a. A match consists of 4 periods of 15 minutes.
- b. At the end of the first and third period there shall be an interval of 2 minutes. During this interval, teams are not permitted to leave the field of play.
- c. Play is resumed by a centre pass. For the second period this is taken by the team that started the first period. For the fourth period the centre pass is taken by the team that started the third period.
- d. At the end of the second period there shall be an interval of 10 minutes. During this interval teams may leave the field of play. Play is resumed by a centre pass which is taken by the team that did not take the centre pass for the first period.
- e. When a penalty corner is awarded, time is stopped for 40 seconds, except in the case of re-awards or penalty corners awarded after a Video Umpire referral.
- f. In the case of a re-awarded penalty corner time will be immediately stopped but the teams will not be allowed an additional 40 seconds. The umpire will re-start play at the earliest possible opportunity, ensuring that any delay is kept to a minimum
- g. The match is prolonged at the end of a period to allow the completion of a penalty corner or any subsequent penalty corner or penalty stroke.
- h. If a match is prolonged at the end of a period to allow for the completion of a penalty corner as specified in the Rules of Hockey, the Umpires will signal the end of that half.
- i. After a goal is scored, time is stopped for 40 seconds, except in the case of goals awarded after a Video Referral and a Penalty Stroke. The umpire will then re- start play, unless time has to be stopped for another reason.

3. TEMPORARY PLAYER SUSPENSIONS

- 3.1 A player who receives a green card (warning) from an Umpire will be temporarily suspended for two (2) minutes of playing time.
- 3.2 A player who receives a yellow card from an Umpire will be temporarily suspended for a minimum of five (5) minutes of playing time. For a more serious offence, this may be increased to ten (10) minutes at the discretion of the Umpire. The duration of a yellow card suspension must be indicated to the technical official on duty by the Umpire who issues the yellow card.
- 3.3 For the duration of each temporary suspension, the offending team plays with one less player.
- 3.4 If a field player receives a green or yellow card, the umpires stop the match, but not necessarily the time to issue the card; if time has been stopped, the Umpires restart immediately after issuing the card.
- 3.5 If a goalkeeper or player with goalkeeping privileges receives a green or yellow card, the umpires stop the match to issue the card and shall re-start the match after the player has left the field of play.
- 3.6 The offending player leaves the field of play immediately; if they interfere with play on their way to the designated suspension area the Umpire may further penalize the player in accordance with the Rules of Hockey.

- 3.7 The period of any temporary suspension starts only when the player is seated in the designated area and the match has been re-started. The timing of the suspension is controlled by the technical official on duty.
- 3.8 The offending player is permitted to resume play when the technical official on duty indicates that the period of suspension has been completed, unless this occurs within the period from the award of a penalty corner until after it has been completed in which case the player cannot return until the corner has been completed or another penalty corner is awarded.
- 3.9 If the offending player is a goalkeeper or player with goalkeeping privileges, the technical official on duty notifies the nearest Umpire when the period of suspension has been completed; the Umpire stops time at the next stoppage in play to enable the player to resume play.
- 3.10 A player can only receive one (1) yellow card in a match. If a second yellow card is given to the same player, this card will automatically be followed by a red card and may be subject to further disciplinary measures by the Tournament Director.

4. PENALTY CORNER COUNTDOWN CLOCK

- 4.1 When a penalty corner is awarded, the timing of the match shall be stopped for 40 seconds as specified in Article 2 above, (inter alia to permit to put on protective gear etc) before allowing the penalty corner to commence. The engaged Umpire shall advise both the defence and the attackers as the shot clock approaches zero. After 40 seconds the Umpire will re-start play by blowing the whistle and the ball shall be injected immediately or very shortly thereafter.
- 4.2 The 40 second clock shall be activated by the technical officials as soon as the penalty corner is awarded and the match clock stopped.
- 4.3 Upon expiry of the 40 seconds the Umpire may allow the taking of the penalty corner. If any team is not ready after 40 seconds, the captain of that team will receive a green card.
- 4.4 The 40 second rule will apply only to the initial award of a penalty corner and not to any retake, or to any second penalty corner awarded before the ball has moved 5m from the circle.
- 4.5 In the event that a team is not ready the umpire is to identify and issue a personal penalty (i.e. a green card) to the player who is responsible for the delay, with an increased personal penalty (i.e. a yellow card) for repeated offences. If this player is a defender, the defending team defends the particular Penalty Corner with one player fewer. For any offence of this rule by a defending goalkeeper or player with goalkeeping privileges, the defending team defends the penalty corner with one fewer player: ie the corner is defended by one fewer player than before this incident. The defending team nominates which defender will be subject to a personal penalty.

5. GOAL SCORING TIMING

- 5.1 When a goal is scored, the Umpires shall (to allow for TV replays and player celebrations) stop the match clock for 40 seconds.
- 5.2 The 40 second clock shall be activated by the technical officials as soon as the goal is scored. Play is not to restart until the 40 second clock has counted down the zero.
- 5.3 Unless otherwise instructed by the Umpires, the match clock shall resume immediately at the expiration of the 40 second period. This is subject to there being no video referral.
- 5.4 Unless otherwise instructed by the Umpires, the match clock shall resume immediately at the expiration of the 40 second period. If any team is not ready after 40 seconds, the captain of that team shall receive a green card.

6. PLAYERS CLOTHING AND EQUIPMENT – FIELD PLAYERS GLOVES

Field players are permitted to wear hand protection which does not artificially increase the size of the hands significantly; any hand protection used, both for normal play and to defend penalty corners, must fit comfortably (without the need for compressing it) into a box open at one end of internal dimensions 290mm long x 180mm wide x 110mm high as illustrated below.

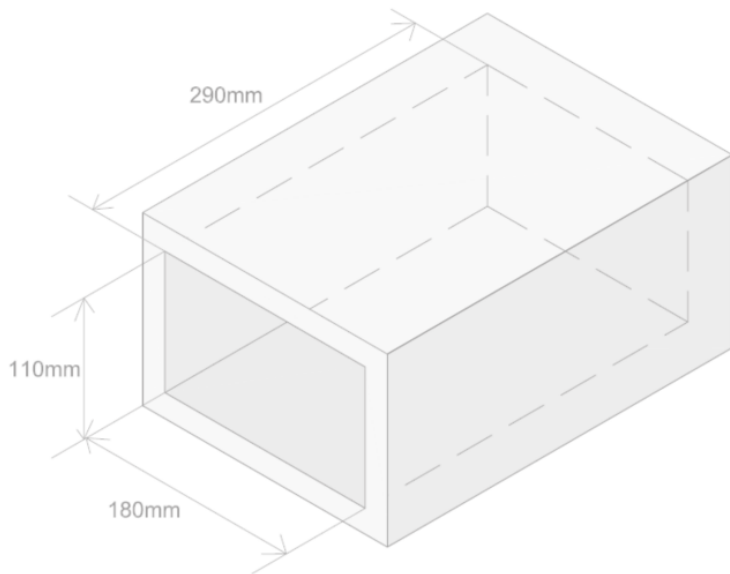

APPENDIX 4 -UNIFORM ADVERTISING

1. MANUFACTURER IDENTIFICATION

An article of clothing or equipment may display the manufacturer's identification in the form of the name, trademark, logo, or any other distinctive sign of the manufacturer of the item, when worn or used by a player, official or umpire whilst playing or officiating in Coal India HIL subject to the following limitations (also see diagram at the end of this section):

- 1.1 on players' shirts, one manufacturer's identification may be displayed either on the non leading arm (lower section of sleeve below the commercial logo if applicable) or on the upper right chest (but not on both). Any such display may not exceed the overall size of 30 cm² per article;
- 1.2 on players' shorts, one manufacturer's identification may be displayed on the back of either short leg up to a maximum size of 42 cm² provided this position has not been used for a commercial logo;
- 1.3 on players' socks, one manufacturer's identification may be displayed on each sock up to a maximum size of 20 cm² per sock.
- 1.4 No visible manufacturer's identification or visible adhesive tape, patch or any other material covering up the identification, is permitted on any t-shirts or shorts worn under the playing kit.
- 1.5 All stripes, panels and secondary colours are considered part of the design and are not regarded as manufacturer's identification.
- 1.6 In respect of outfield players' gloves and armbands, one manufacturer's identification per item will be permitted up to a maximum size of 6 cm².
- 1.7 There is no restriction on equipment, headgear or shoes.

2. SPONSOR IDENTIFICATION

- 2.1 Commercial sponsorship and advertising in the form of a company's name, logo or trademark is permitted on shirts and shorts as follows and is measured as the area within a rectangle drawn around the advertisement (also see diagram at the end of this section):
- 2.2 on players' shirts, up to twelve commercial logos may be displayed as follows:
 - (a) on the front of the player's shirt - up to 350 cm²;
 - (b) on the leading arm upper sleeve and lower sleeve - each up to 42 cm²;
 - (c) on the non-leading arm upper sleeve and lower sleeve - each up to 42 cm²;
 - (d) on both collars - each up to 36 cm² (where a team wears a singlet style shirt (i.e. no collar) replacement advertisements of size not exceeding 36 cm² each may be placed near the neckline of the shirt);
 - (e) on the right chest - up to 42 cm²;
 - (f) on both side panels - each up to 100 cm²;
 - (g) on the back, top and bottom - each up to 200 cm².
- 2.3 on players' shorts, up to three commercial logos may be displayed as follows:
 - (a) on the right leg of the front of the player's shorts - up to 80 cm²;
 - (b) on the right leg of the back of the player's shorts - up to 80 cm²;
 - (c) on the back of the player's shorts centrally below the waistline - up to 80 cm²;
- 2.4 Any commercial logo on clothing shall be decided by each team and shall be common to and worn by each member of the team concerned. No individual commercial logos shall be worn by any team member, except for those manufacturer's logos displayed on sticks or shoes.

- 2.5 Subject to the limitations contained in these regulations, both teams may display any commercial logo on its clothing or equipment irrespective of whether such logos may conflict with any sponsor or supplier of the host team or their venue.
- 2.6 Both teams shall abide by any law of the host venue, which restricts advertising of a product. No compensation shall be payable should a team be precluded from displaying its commercial logos on hockey clothing or hockey equipment, and a visiting team shall not pursue any action against the host team in this respect.
- 2.7. The commercial logos on the practice kit may reflect those of the playing kit. For the avoidance of doubt there must be no logo featured on the waistband.
- 2.8 Care should be taken to ensure that there is ample space between all elements to provide maximum legibility in all media and when the shirt is tucked into the shorts. All names must be printed along the same path, to preserve the consistency of the Coal India HIL brand.
- 2.9 Each player may display individual commercial sponsorship or advertising on his hockey stick, subject to the following conditions:
- (a) a single company logo, name, trademark or advertisement may appear twice on the hockey stick - once on the playing side and once on the reverse;
 - (b) each logo, name, trademark or advertisement must be no larger than 15 cm x 4 cm;
 - (c) the branding must not conflict with any stick regulations, and the stick must remain smooth on both surfaces and pass all regulation stick checks;
 - (d) the stick sponsorship is individual to each player and therefore can vary within a team;
 - (e) both Coal India HIL and the Franchise reserve the right to refuse a player's stick advertising if it is deemed inappropriate or is in conflict with Coal India HIL or team commercial arrangements.
- 2.10 Throughout all of the above, no team or player sponsorship or advertising will be allowed which includes alcohol, tobacco, or tobacco related products.

3. COAL INDIA HIL AND TEAM IDENTIFICATION

Team and Coal India HIL identification is allowed on playing kit as follows:

- 3.1 A team may display its team identification or logo on the upper left chest of the playing shirts, size not exceeding 60 cm².
- 3.2 The Coal India HIL logo must be displayed on the leading arm lower sleeve.
- 3.3 Nothing contained herein shall prevent the team logo and/or the name of the team from being incorporated as part of the design of the playing shirts used in the Coal India HIL.

4. DESIGN AND COLOURS

- 4.1 Each team is entitled to determine the design for its playing kit subject to the restrictions contained within the Coal India HIL Regulations (see **Section 6**), and as approval by Coal India HIL. Team colours shall be given on first come first basis.
- 4.2 The colours and design of the shirts, shorts and socks shall be uniform to all members of the same team.
- 4.3 Each item of clothing (shirts, shorts and socks), must have at least 80% of the stated colour in the design.

5. GENERAL

- 5.1 Only training kit (e.g. tracksuits, sweatshirts, branded t-shirts, bibs, etc.) issued by the team (the team training kit) may be worn by the players and team officials within the precincts of the venue on match days as well as at all official team practice and training sessions.

- 5.2 No team training kit is to be worn by players on the field of play during a match, except when sitting on the bench, or when warming up on the sideline (which must include a bib as described in Regulation 6.4).
- 5.3 Players or team officials attending post match presentation ceremonies and press conferences,

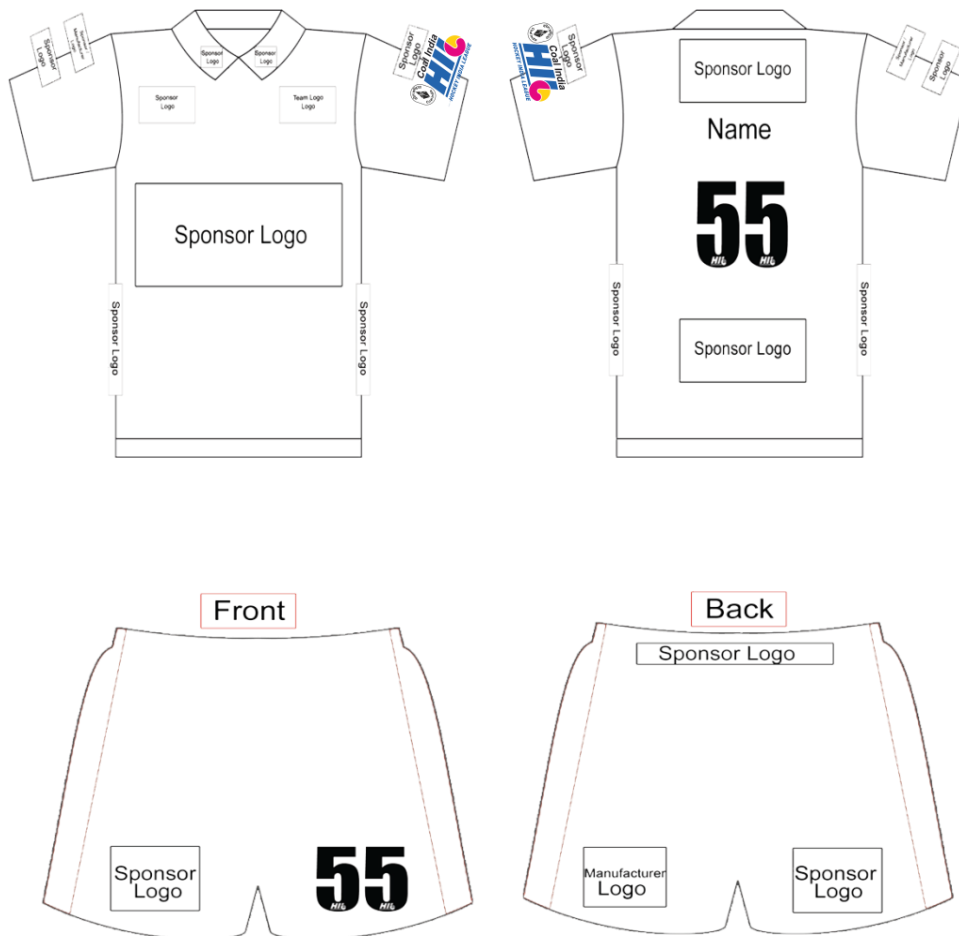

including television interviews conducted before, during or after the match, are required to wear either team playing clothing or team training kit (excluding bibs).

6. UMPIRES AND OFFICIALS UNIFORM

- 6.1 Advertising in the form of a company's name, logo or trademark or any other distinctive sign of the manufacturer is permitted when expressly authorised by Coal India HIL, as described below:
- on the front of the umpires/officials' shirts - size not exceeding 350 cm²;
 - on the back of the umpires/officials' shirts, below the umpire's name - size not exceeding 350 cm²;
 - Coal India HIL may add an Coal India HIL and/or HI logo to the umpires/officials uniform, with no restriction on size of the logo.

APPENDIX 5 –VIDEO UMPIRE PROCEDURES

APPLICATION

The Video Umpire procedure will be used in all Coal India HIL 2017 matches.

1. POWER TO REFER DECISION TO THE VIDEO UMPIRE

- 1.1 The Match Umpires are the only persons who can refer decisions to the Video Umpire either directly or after a request from a team;
- 1.2 Referrals cannot be made as a result of protests, queries or pressure from players, Team Managers or Coaches on any decision. Teams (and their captains) will be held responsible for any violation or abuse of the Video Umpire protocols;
- 1.3 No one other than the Match Umpires, can stop the match to request a referral; eg the Video Umpire or Technical Officials at the Technical Table cannot stop a match.

2. UMPIRE REFERRAL

- 2.1 The Match Umpires may refer decisions to the Video Umpire when they are not convinced that they have taken, or are able to take, the correct decision relating to the awarding or disallowing of goals.
- 2.2 Referrals shall only relate to whether or not a goal has been legally scored.
- 2.3 The match Umpires are therefore entitled to request the Video Umpire to assist in making decisions which include, but are not restricted to:
 - a whether the ball crossed the goal line (within the area bounded by the goal posts and crossbar);
 - b whether the ball was legally played or touched inside the circle by the stick of an attacker and did not travel outside the circle before passing completely over the goal-line and under the cross-bar;
 - c whether the ball travelled outside the circle before it entered the goal either from a shot by an attacker during the taking of a penalty corner;
 - d whether a breach of the Rules has been observed within the attacking 23 metre area in the play leading to the awarding or disallowing of a goal. It is then for the Match Umpire to take any breach into account in reaching their decision.
- 2.4 The Match Umpire requests Video Umpire assistance using the "television-screen" signal; he / she relays by radio to the Video Umpire whatever information is necessary.

3. UMPIRE REFERRAL PROCESS

- 3.1 The Video Umpire calls for as many replays from any camera angle as necessary to reach a decision.
- 3.2 Within the shortest time frame possible, the Video Umpire provides his / her advice and recommendation:
 - 'Goal'
 - 'No Goal'
 - 'No Advice Possible'
 - plus advice on any observed breach of the Rules.
- 3.3 If a breach of the Rules is observed and advised to the match Umpire, it is then for the Match Umpire to take into account the breach in reaching his / her final decision.
- 3.4 In the case of 'No Advice Possible' (if the video footage is inconclusive, including through not having the correct replays available, the ball never being in shot in the replays, the footage being of insufficient quality to permit a decision or technical problems with the referral equipment) the original decision of the Match Umpire stands. If there was no decision given before the referral, then the final decision is 'No Goal'.

- 3.5 An umpire referral that has already been adjudicated upon may not be the subject of a subsequent team referral.

4. TEAM REFERRAL

- 4.1 Each team is allowed one team referral request (which must be made through the Match Umpires) during regulation time in any match subject to articles 5.4a and 5.4b below of this Regulation and one team referral request during a shoot-out competition, subject to articles 5.4a and 5.4b below:
- a team referrals will be restricted to decisions within the 23 metre areas relating to the award (or non-award) of goals, penalty strokes and penalty corners and, during a shoot-out competition, whether a shoot-out should be re-taken. The award of personal penalty cards may not be the subject of a team referral;
 - b any team player, on the field of play at the time of the incident, can request a team referral;
 - c this player must indicate to a Match Umpire that he / she wishes to use their team referral. He / she must do so immediately after the incident or decision which is to be referred by using the 'T' signal as well as confirming this verbally to the Umpire;
 - d the Match Umpires will not disallow any request for a team referral provided the 'T' signal has been used by a player and seen by the umpire;
 - e the player requesting the team referral must inform a Match Umpire of the exact nature of the decision (or non-decision) that their team wishes to be reviewed within a maximum of 20 seconds;
 - f if no question is received within 20 seconds the team referral will automatically default to a review of the last decision or non-decision relating to the award (or non-award) of a goal, penalty stroke, penalty corner or re-take of a shoot-out;
 - g the Match Umpire then requests Video Umpire assistance using the "television-screen" signal, followed by a 'T' signal to denote a team referral; he / she relays by radio to the Video Umpire whatever information is necessary.

5. TEAM REFERRAL PROCESS

- 5.1 The Video Umpire calls for as many replays from any camera angle as necessary to reach a decision.
- 5.2 Within the shortest time frame possible, the Video Umpire provides his / her advice and recommendation:
- 'Goal'
 - 'No Goal'
 - 'Penalty Stroke'
 - 'No Penalty Stroke'
 - 'Penalty Corner'
 - 'No Penalty Corner'
 - 'Shoot-out to be re-taken'
 - 'No shoot-out re-take'
 - 'No Advice Possible'
 - plus advice on any observed breach of the Rules.
- 5.3 If a breach of the Rules is observed and advised to the Match Umpire, it is then for the Match Umpire to take into account the breach in reaching his / her final decision.

- 5.4 Implications for the retention or loss of team referral rights:
- a in the event that the referral is upheld the referring team retains its right of referral;
 - b in the event of 'No Advice Possible' (if the video footage is inconclusive, including through not having the correct replays available, the ball never being in shot in the replays, the footage being of insufficient quality to permit a decision or technical problems with the referral equipment), the referring team retains its right of referral;
 - c if there is no clear reason to change the Match Umpire's original decision, the referring team loses its right of referral.
- 5.5 A team referral that has been already been adjudicated upon may not be the subject of a subsequent referral by the opposing team.

6. FOR UMPIRE AND TEAM REFERRALS

- 6.1 The final decision, including any matter of interpretation, remains with the Match Umpire and not the Video Umpire.
- 6.2 All other decisions remain with the Match Umpires.
- 6.3 Substitutions may not take place during the stoppage of play for a video referral; substitution may take place on the resumption of play subject to the Rules of Hockey.

APPENDIX 6 – BREACH OF OVERSEAS PLAYER NUMBERS

1. INTRODUCTION

Coal India HIL regulation 5.4 requires that *‘No less than 2 and no more than 5 overseas (non-Indian) players may be on the pitch for each team at any time during the match, including the goalkeeper (also see Clause 9.4 regarding substitutions). If a shoot-out is played in a play-off match, no more than 3 overseas players may be used by each team to take a shoot-out. During a shoot-out, the goalkeeper can be of any nationality.’*

Coal India HIL regulation 9.4 states that *‘Team Managers’ are responsible for advising the Technical Officer on duty of the substitution of any overseas (non-Indian) players during the match.’*

In order to ensure that this procedure is followed, each Team Manager will be issued with 8 coloured ‘Foreign Player’ cards (one for each of their overseas players). At the start of the game, and whenever making a substitution of an overseas player, the Team Manager must hand to the Technical Table the appropriate Foreign Player card for the player going onto the pitch. At the same time, the Team Manager can collect the Foreign Player card of the player coming off the pitch (if appropriate). This method will ensure that the Technical Officials are always aware of the correct number of overseas players on the pitch at any point in the match.

2. SANCTIONS

Should a team breach the requirements of Coal India HIL Regulation 5.4 by having either too few or too many overseas (non-Indian) players on the pitch at any time during a match or shoot-out the following will occur:

3. TOO FEW OVERSEAS (NON-INDIAN) PLAYERS

1. As soon as the breach has been realised or reported, the TO will advise the relevant Team Manager of the regulation breach. The Team Manager will amend the player combination by immediate substitution of the relevant player(s).
2. At the completion of the match, the TO will immediately submit a written report of the incident to the ATD on duty, who will treat it as a breach of the Coal India HIL Code of Conduct and investigate it accordingly, keeping the TD informed at all times.
3. The Team Manager must make himself available immediately after the match to answer the breach of Coal India HIL Code of Conduct.

4. TOO MANY OVERSEAS (NON-INDIAN) PLAYERS

1. As soon as the breach has been realised or reported, the TO will advise the relevant Team Manager of the Regulation breach. The Team Manager will amend the player combination by immediate substitution of the relevant player(s).
2. As soon as possible after the breach, the umpire(s) will be advised of the breach and will award a Penalty Corner against the offending team.
3. At the completion of the match, the TO will immediately submit a written report of the incident to the ATD on duty, who will treat it as a breach of the Coal India HIL Code of Conduct and investigate it accordingly, keeping the TD informed at all times.

4. The Team Manager must make himself available immediately after the match to answer the breach of the Coal India HIL Code of Conduct.